

- FIBER SENSORS
- LASER SENSORS
- PHOTOELECTRIC SENSORS
- MICRO PHOTOELECTRIC SENSORS
- AREA SENSORS
- SAFETY LIGHT CURTAINS / SAFETY COMPONENTS
- PRESSURE / FLOW SENSORS
- INDUCTIVE PROXIMITY SENSORS
- PARTICULAR USE SENSORS
- SENSOR OPTIONS
- SIMPLE WIRE-SAVING UNITS
- WIRE-SAVING SYSTEMS
- MEASUREMENT SENSORS
- STATIC CONTROL DEVICES
- LASER MARKERS**
- PLC
- HUMAN MACHINE INTERFACES
- ENERGY MANAGEMENT SOLUTIONS
- FA COMPONENTS
- MACHINE VISION SYSTEMS
- UV CURING SYSTEMS
- Selection Guide
- FAYb Laser
- CO2 Laser
- Option
- LP-M
- LP-S**
- LP-S500W
- LP-RF
- LP-Z
- LP-V/LP-W

Related Information ■ General terms and conditions..... F-3 ■ Selection guide P.1223~
 ■ About laser beam..... P.1593~ ■ Korea's KC-mark P.1602



panasonic.net/id/pidsx/global

FDA
Conforming to FDA regulations

GB
Conforming to 7247.1

This product is classified as a Class 4 Laser Product in IEC / JIS standards and in FDA* regulations. Never look at or touch the direct laser beam and its reflection.

* This product complies with 21 CFR 1040.10 and 1040.11 Laser Notice No. 50, dated June 24, 2007, issued by CDRH.

FAYb laser enabling deep engraving and high-speed marking

HIGH OUTPUT

High output for superior deep engraving performance

The 42 W high-power output enables high-speed deep engraving and black marking on metal workpieces. This allows for quick and accurate marks to be performed on precision metal parts, such as tweezers and medical instruments.

■ Cross-section image of engraved location

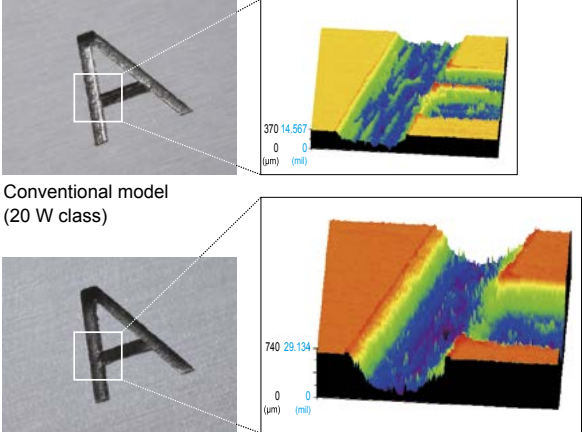

LP-S500 [Almost double the depth with the same takt time*]
* Varies depending on workpiece.

High speed for enhanced productivity

Faster and deeper marking or processing is possible as more energy is applied to the workpiece. The **LP-S500** is equipped with a high-output laser unit. This shortens the printing takt time greatly contributing to the improvement of productivity.

■ Simulated characteristics of high-speed deep engraving

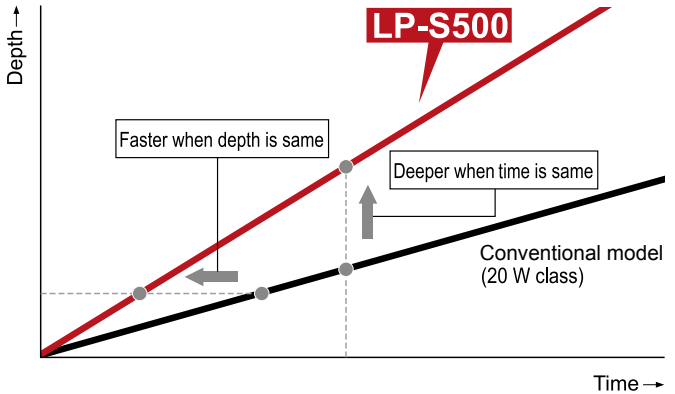

MARKING EXAMPLES



Highly efficient and energy-saving

Conversion loss is minimal as the FAYb laser amplifies the laser beams in the fiber, achieving excellent beam-to-beam conversion efficiency of approximately 50 %. Power consumption is minimized despite the high output, contributing to reduction in CO₂ emission.

Oscillation principle of FAYb laser

The FAYb laser is a revolutionary whereby low intensity laser beams emitted from the master oscillator are amplified as they pass through a Ytterbium (Yb) treated fiber, resulting in a stronger laser beam output.

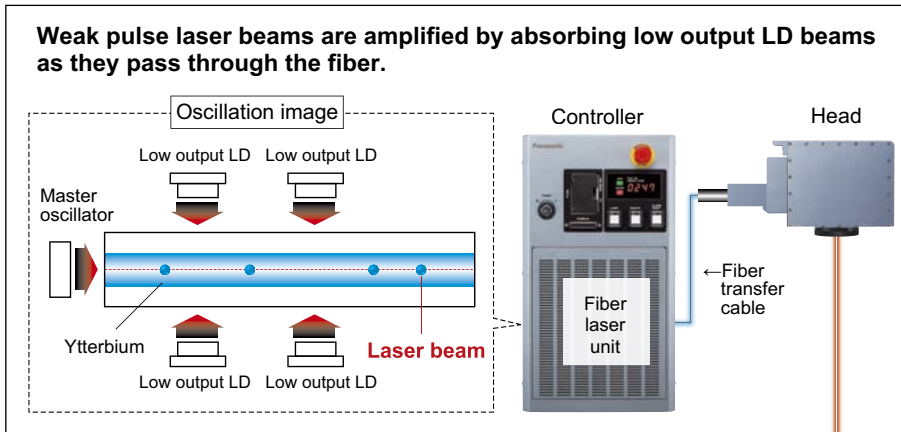

ENVIRONMENT RESISTANCE

Sealed, IP67G rated head enclosure

Superior design

The LP-S series features minimum frame seams. Minor seams and screw holes are completely sealed, producing high sealing performance. This performance is sustained by applying constant pressure to the sealed areas. Maximum cooling efficiency is also achieved allowing the use of a fanless head for thorough cooling.

High quality protection parts

Seamless sealing materials are used that have low water absorption and excellent oil resistance properties. Connectors are dust, water, and oil-proof. The lens has a protective glass cover.

■ Composition

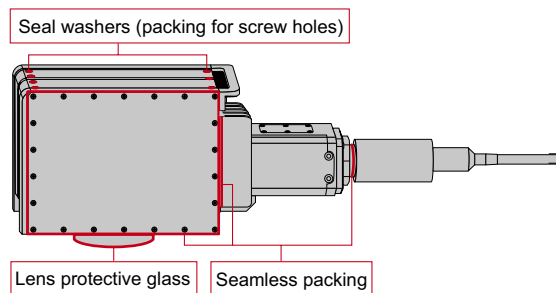

What is IP?
IP indicates the degree of protection from water, human body, or solid foreign objects.
This is based on IEC / JIS standards.

- IP6X: Prevents chips from entering inside the product (complete prevention).
- IPX7: Prevents water from entering inside the product when it is immersed under water under the specified conditions.
- G: Indicates the oil protection structure specified by JIS standards and able to prevent oil drops or oil foam from entering from any direction.

FIBER SENSORS

LASER SENSORS

PHOTOELECTRIC SENSORS

MICRO PHOTOELECTRIC SENSORS

AREA SENSORS

SAFETY LIGHT CURTAINS / SAFETY COMPONENTS

PRESSURE / FLOW SENSORS

INDUCTIVE PROXIMITY SENSORS

PARTICULAR USE SENSORS

SENSOR OPTIONS

SIMPLE WIRE-SAVING UNITS

WIRE-SAVING SYSTEMS

MEASUREMENT SENSORS

STATIC CONTROL DEVICES

LASER MARKERS

PLC

HUMAN MACHINE INTERFACES

ENERGY MANAGEMENT SOLUTIONS

FA COMPONENTS

MACHINE VISION SYSTEMS

UV CURING SYSTEMS

Selection Guide

FAYb Laser

CO₂ Laser

Option

LP-M

LP-S

LP-S500W

LP-RF

LP-Z

LP-V/LP-W

FIBER
SENSORSLASER
SENSORSPHOTOELECTRIC
SENSORSMICRO
PHOTOELECTRIC
SENSORSAREA
SENSORSSAFETY LIGHT
CURTAINS /
SAFETY COMPONENTSPRESSURE /
FLOW
SENSORSINDUCTIVE
PROXIMITY
SENSORSPARTICULAR
USE SENSORSSENSOR
OPTIONSSIMPLE
WIRE-SAVING
UNITSWIRE-SAVING
SYSTEMSMEASUREMENT
SENSORSSTATIC
CONTROL
DEVICESLASER
MARKERS

PLC

HUMAN MACHINE
INTERFACESENERGY
MANAGEMENT
SOLUTIONS

FA COMPONENTS

MACHINE VISION
SYSTEMSUV CURING
SYSTEMSSelection
Guide

FAYb Laser

CO₂ Laser

Option

LP-M

LP-S

LP-S500W

LP-RF

LP-Z

LP-V/LP-W

USER-FRIENDLY**Removable fiber unit enhanced flexibility of equipment design**

Panasonic's unique laser head design allows the fiber unit to be easily removed from the scanner unit. This revolutionary mechanism is a first in the fiber laser marker industry^{*1}. Because the fiber unit is removable, it can be easily incorporated into equipment for easy installation and enhanced flexibility of equipment design.

■ View showing fiber unit removal

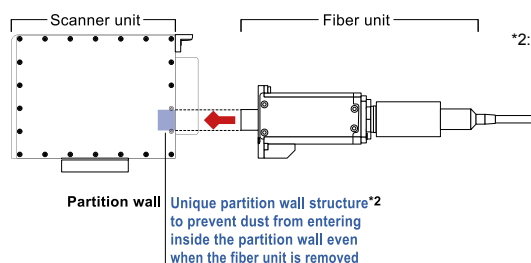

Unique partition wall structure^{*2} to prevent dust from entering inside the partition wall even when the fiber unit is removed

*1: Data obtained by Panasonic Industrial Devices SUNX as of December 2010

*2: The IP67G protected structure is effective when the fiber unit and connectors are attached correctly. If any dust sticks to the removed section or partition wall, printing performance may be affected. Remove the fiber unit in a clean environment, and be sure to turn OFF the power before removal.

[Fiber unit removability advantages]

- Smaller equipment, lower costs
- Simpler equipment assembly
- Simpler dismantling when transporting equipment
- Simpler laser marker maintenance

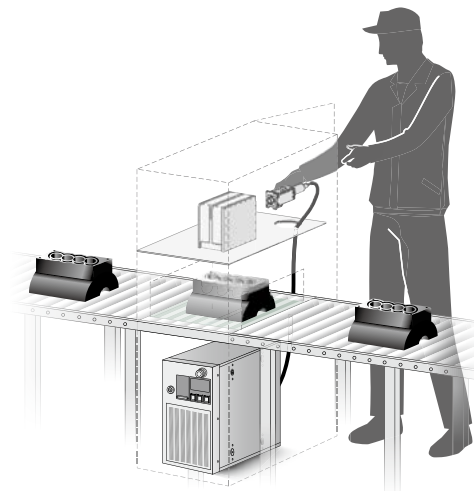

■ Illustration showing fiber unit removal

OPERABILITY**Easy operation via a touch panel console**

A color touch panel is used so that even persons unfamiliar with machine operation can easily handle it. An intuitive and easily understandable software package allows the operator to smoothly access any setting screens, and the ergonomically designed console is easy to operate whether hand-held or directly attached to a machine.

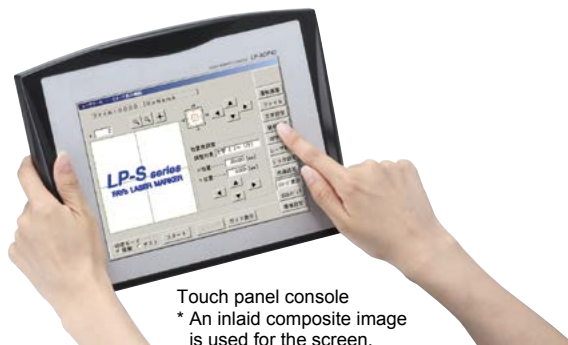

Touch panel console
* An inlaid composite image is used for the screen.

Configurable using an office PC

The laser marker comes standard with PC software that allows for easy configuration of print data and layout, via a familiar PC based environment. Data can also be created on a PC in offline mode, which means that data configuration is possible without stopping the laser marker. In addition, connecting a PC to the laser marker allows you to check the operation status, I/O status or error log.

Monitor and mouse**Large screen for checking print content**

Laser marker setup and operation is made simple by connecting a commercially available monitor and a mouse. When the monitor is placed in an easy-to-view position, the printed content can be viewed from a distance and any changes made to the printed content can easily be verified.

* Operation check is required in advance.

SPECIFICATIONS

Item	Type Model No.	LP-S500			LP-S200		
		Standard LP-S500	Small spot LP-S502	Wide-area LP-S505	Standard LP-S200	Small spot LP-S202	Wide-area LP-S205
CE marking directive compliance		Low Voltage Directive, EMC Directive, RoHS Directive					
Work distance (Note 1)		190 mm 7.480 in	130 mm 5.118 in	350 mm 13.780 in	190 mm 7.480 in	130 mm 5.118 in	350 mm 13.780 in
Marking laser		Class 4 Yb fiber laser; wavelength: 1,064 nm 0.042 mil					
Average output (Note 2)		42 W (±5 %) (pulse oscillation)			17 W (±5 %) (pulse oscillation)		
Guide laser / pointer		Class 2 semiconductor laser; wavelength: 655 nm 0.026 mil					
Marking range		90 × 90 mm 3.543 × 3.543 in	55 × 55 mm 2.165 × 2.165 in	160 × 160 mm 6.299 × 6.299 in	90 × 90 mm 3.543 × 3.543 in	55 × 55 mm 2.165 × 2.165 in	160 × 160 mm 6.299 × 6.299 in
Scanning method		Galvano scanning method					
Character settings (character height, width) (Note 3)		0.1 to 90 mm 0.004 to 3.543 in	0.1 to 55 mm 0.004 to 2.165 in	0.1 to 160 mm 0.004 to 6.299 in	0.1 to 90 mm 0.004 to 3.543 in	0.1 to 55 mm 0.004 to 2.165 in	0.1 to 160 mm 0.004 to 6.299 in
Marking spacing (character spacing, line pitch) (Note 3)		0 to 90 mm 0 to 3.543 in	0 to 55 mm 0 to 2.165 in	0 to 160 mm 0 to 6.299 in	0 to 90 mm 0 to 3.543 in	0 to 55 mm 0 to 2.165 in	0 to 160 mm 0 to 6.299 in
Marking shape		Arced output: -180° to +180° (variable in 0.01° steps)					
Marking shape		Straight Line, Proportional, Justify, Arc					
Character types		English uppercase letters, English lowercase letters, numerals, katakana, hiragana, kanji (JIS No. 1 and No. 2 standards), symbols, user-registered characters (up to 50)					
Barcodes		Code 39, Code 128, ITF, NW-7, JAN/UPC, RSS-14 (GS1 DataBar), RSS (GS1 DataBar), Limited, RSS (GS1 DataBar), Expanded					
2D codes		QR Code, Micro QR Code, Data Matrix, GS1 Data Matrix					
Composite codes		RSS-14 (GS1 DataBar) CC-A, RSS-14 (GS1 DataBar) Stacked CC-A, RSS (GS1 DataBar) Limited CC-A, UCC / EAN COMPOSITE etc.					
I/O		Input terminal, Output terminal, I/O connector					
Interface		RS-232C, Ethernet					
Cooling method		Head: Naturally air cooling, Controller: Forced air cooling					
Power supply		90-132 V AC, or 180-264 V AC (automatic switching), 50/60 Hz					
Power consumption		530 VA or less (100 V AC), 650 VA or less (200 V AC)			330 VA or less (100 V AC), 450 VA or less (200 V AC)		
Protection degree		Head: IP67G					
Ambient temperature		0 to +40 °C +32 to +104 °F (Controller, Head) (No dew condensation or icing allowed)					
Storage ambient temperature		-10 to +60 °C +14 to +140 °F (Controller, Head) (No dew condensation or icing allowed)					
Ambient humidity		35 % to 85 % RH (Controller, Head) (No dew condensation or icing allowed)					
Applicable standards		FDA regulations, CE marking (Note 4)					
Net weight	Head	7.5 kg approx.	7.5 kg approx.	8 kg approx.	7.5 kg approx.	7.5 kg approx.	8 kg approx.
	Controller	25 kg approx.			24 kg approx.		
Laser Marker Utility OS (Note 5)		Microsoft Windows® 10 Professional (32-bit / 64-bit) / 8 Professional (32-bit / 64-bit) / 7 Professional (32-bit / 64-bit) / Vista Business (32-bit) / XP Professional (32-bit)					

- Notes: 1) Work distance varies by approx. ±0.5 mm **±0.020 in** from model to model. (**LP-S505** and **LP-S205**: approx. ±2 mm **±0.079 in**)
 2) This output is measured at the work end. (The preset power is 100.)
 3) Variable in 0.001 mm **0.0004 in** steps.
 4) China models are available, too. Please contact our sales office.
 5) Microsoft and Windows are trademarks or registered trademarks of Microsoft Corporation in the United States and other countries.

[Dust-, water- and oil-proof performance]

- The head of the FAYb Laser Marker (excluding controller) offers dust- and water-proof performance conforming to IEC / JIS protection grade IP67. Oil-proof performance conforms to IPXXG, and offers protection against some lubricant and cutting oils. Tests are conducted according to the specified environments, times, and methods. However, dust-, water- and oil-proof performance is not guaranteed in all environments. Refer to IEC 60529 (JIS C 0920) for details of testing methods. Oil-proof performance is evaluated using typical lubricants and cutting oils (see table below), but this performance may not be fully achieved depending on the type of oil.
- The protection degree fully achieves performance only when the fiber unit, connectors, focus adjustment unit cover and lens protection glass are attached correctly.
- Although the product features a protection degree, it cannot be used submersed in water or oil.

Test oils	Oil type	Product name	Oil type	Product name
		Water-insoluble cutting oil	Yushiron Cut Abas BM405	Lubricant
	Water-soluble cutting oil	Daphne Alpha Cool EW, Yushiroken EC50T5	Machine oil	Daphne Mechanic Oil 46

FIBER SENSORS

LASER SENSORS

PHOTO-ELECTRIC SENSORS

MICRO PHOTO-ELECTRIC SENSORS

AREA SENSORS

SAFETY LIGHT CURTAINS / SAFETY COMPONENTS

PRESSURE / FLOW SENSORS

INDUCTIVE PROXIMITY SENSORS

PARTICULAR USE SENSORS

SENSOR OPTIONS

SMILE WIRE-SAVING UNITS

WIRE-SAVING SYSTEMS

MEASUREMENT SENSORS

STATIC CONTROL DEVICES

LASER MARKERS

PLC

HUMAN MACHINE INTERFACES

ENERGY MANAGEMENT SOLUTIONS

FA COMPONENTS

MACHINE VISION SYSTEMS

UV CURING SYSTEMS

Selection Guide

FAYb Laser

CO2 Laser

Option

LP-M

LP-S

LP-S500W

LP-RF

LP-Z

LP-V / LP-W

PRECAUTIONS FOR PROPER USE

Refer to p.1593~ for information about laser beam.

- This catalog is a guide to select a suitable product. Be sure to read instruction manual attached to the product prior to its use.

- This product is classified as a Class 4 Laser Product in IEC / JIS standards and in FDA* regulations. Never look at or touch the direct laser beam and its reflection.
- The laser used by this product generates infrared light that is invisible to the human eye. Use particular caution when the laser is operating.
- The following labels are attached to this product. Handle the product according to the instruction given on the warning labels. (Warning labels are not shown in the product photographs in this catalog.)



* This product complies with 21 CFR 1040.10 and 1040.11 Laser Notice No. 50, dated June 24, 2007, issued by CDRH.

Safety standards for laser beam products

- A laser beam can harm human being's eyes, skin, etc., because of its high energy density. IEC has classified laser products according to the degree of hazard and the stipulated safety requirements. The **LP-S** series are classified as Class 4 laser.

Overview of classification by IEC 60825-1

Classification	Description
Class 4	Lasers that are also capable of producing hazardous diffuse reflections. They may cause skin injuries and could also constitute a fire hazard.

Safe use of laser products

- For the purpose of preventing user from suffering injuries by laser products, IEC 60825-1 (Safety of laser products). Kindly check the standards before use.

Recommended use of a dust collector

- Depending on the object being marked, harmful gasses or smoke that have a detrimental effect on the human body or the laser marker may be generating during marking. If your application falls under this description, use a dust collector.

* For more information, contact our office.

Maintenance

- Air filter: Regularly clean the air filter attached to the FAYb Laser Marker to maintain cooling effects.
- Laser pointer emission port: Dust or chips adhering to the laser pointer emission port may affect the printing quality or seriously damage the laser marker. Clean the laser pointer emission port regularly.

- FIBER SENSORS
- LASER SENSORS
- PHOTO-ELECTRIC SENSORS
- MICRO PHOTO-ELECTRIC SENSORS
- AREA SENSORS
- SAFETY LIGHT CURTAINS / SAFETY COMPONENTS
- PRESSURE / FLOW SENSORS
- INDUCTIVE PROXIMITY SENSORS
- PARTICULAR USE SENSORS
- SENSOR OPTIONS
- SIMPLE WIRE-SAVING UNITS
- WIRE-SAVING SYSTEMS
- MEASUREMENT SENSORS
- STATIC CONTROL DEVICES
- LASER MARKERS
- PLC
- HUMAN MACHINE INTERFACES
- ENERGY MANAGEMENT SOLUTIONS
- FA COMPONENTS
- MACHINE VISION SYSTEMS
- UV CURING SYSTEMS

- Selection Guide
- FAYb Laser
- CO2 Laser
- Option

- LP-M
- LP-S**
- LP-S500W
- LP-RF
- LP-Z
- LP-V/ LP-W

DIMENSIONS (Unit: mm in)

The CAD data can be downloaded from our website.

Head

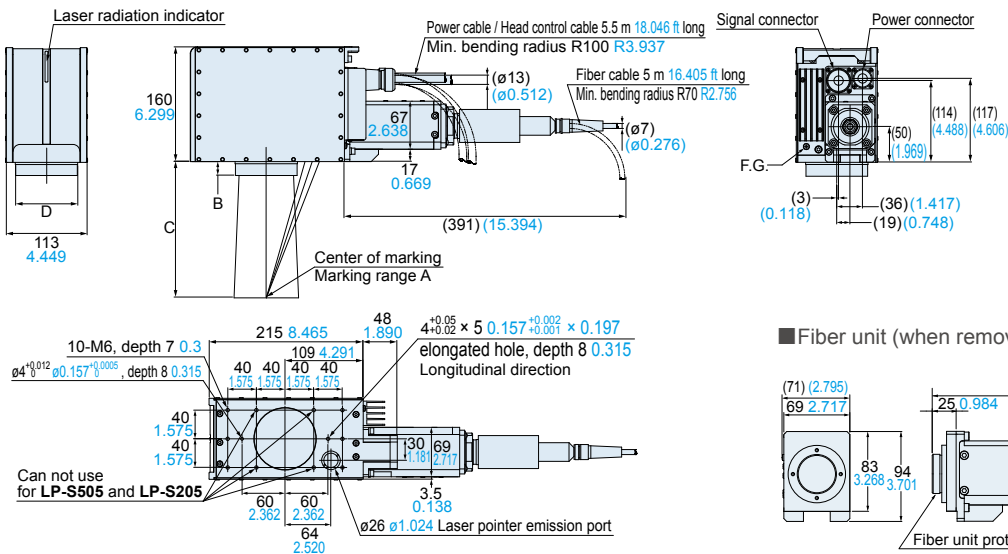

	LP-S500 LP-S200	LP-S502 LP-S202	LP-S505 LP-S205
A	90 × 90 3.543 × 3.543	55 × 55 2.165 × 2.165	160 × 160 6.299 × 6.299
B	(20)(0.787)	(22)(0.866)	(41)(1.614)
C	190 7.480	130 5.118	350 13.780
D	ø87 ø3.425	ø92 ø3.622	ø106 ø4.173

Fiber unit (when removed)

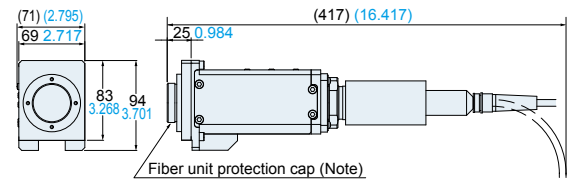

Note: The fiber unit protection cap should be removed when the scanner unit is connected.

Controller

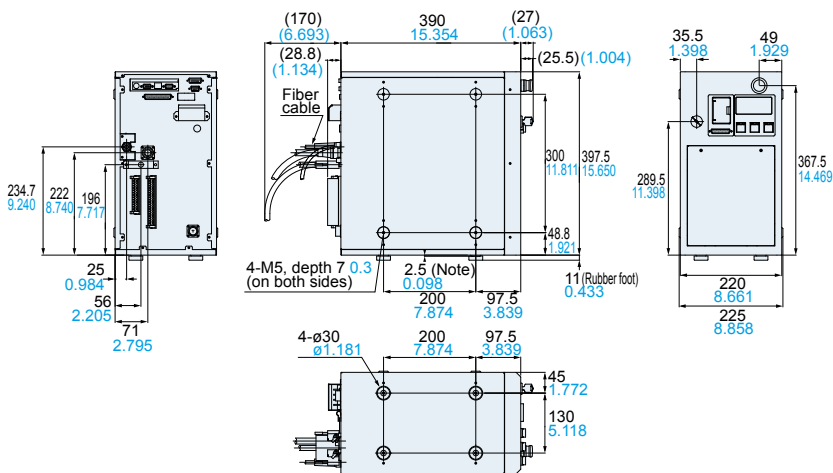

Note: Indicates the height at the protruding section when the rubber foot are not attached. The rubber foot can be attached to either the right or left side of the controller.

LP-ADP40

Console (Optional)

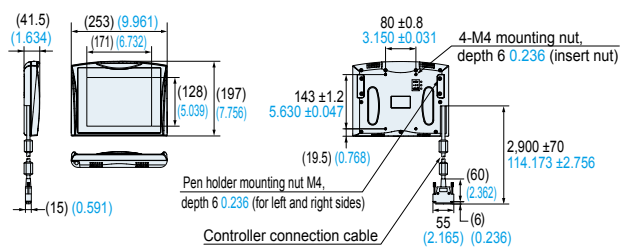

FIBER SENSORS

LASER SENSORS

PHOTO-ELECTRIC SENSORS

MICRO PHOTO-ELECTRIC SENSORS

AREA SENSORS

SAFETY LIGHT CURTAINS / SAFETY COMPONENTS

PRESSURE / FLOW SENSORS

INDUCTIVE PROXIMITY SENSORS

PARTICULAR USE SENSORS

SENSOR OPTIONS

SMILE WIRE-SAVING UNITS

WIRE-SAVING SYSTEMS

MEASUREMENT SENSORS

STATIC CONTROL DEVICES

LASER MARKERS

PLC

HUMAN MACHINE INTERFACES

ENERGY MANAGEMENT SOLUTIONS

FA COMPONENTS

MACHINE VISION SYSTEMS

UV CURING SYSTEMS

Selection Guide

FAYb Laser

CO2 Laser

Option

LP-M

LP-S

LP-S500W

LP-RF

LP-Z

LP-V / LP-W